

Design and Construction of a Dual Powered Reverse Osmosis Based Mobile Water Treatment Plant for Military and Emergency Use

R. S Hamalai¹, A. Sadiq¹. & D.K Garba¹

Department of Mechanical Engineering Nigerian Defence Academy,
Kaduna P.M.B 2109, Kaduna, Nigeria

Received: 21 June 2024; **Accepted:** 22 July 2024; **Published:** 26 August 2024

To cite this article (APA): Hamalai, R. S., Sadiq, A., & Garba, D. (2024). Design and Construction of a Dual Powered Reverse Osmosis Based Mobile Water Treatment Plant for Military and Emergency Use. *EDUCATUM Journal of Science, Mathematics and Technology*, 12(1), 118–133. <https://doi.org/10.37134/ejsmt.vol12.1.12.2025>

To link to this article: <https://doi.org/10.37134/ejsmt.vol12.1.11.2025>

ABSTRACT

A mobile water treatment plant was designed, constructed and tested to provide potable drinking water from almost all-natural water sources during military operations and emergency situations. The treatment plant was designed to fit into a Tata LPTA 713/32 military grade truck with payload capacity of 2500kg. In order to design a plant to treat water from different sources, several water treatment methods were analyzed including existing mobile water treatment plants in the Nigerian Defence Academy (NDA) to give a combination of treatment processes that effectively treat 2.16 m³ of water per day serving 505 cadets their daily water requirements with no time lapse per treatment cycle within a short period of time. The treatment flow process majorly involves the use of ion exchange unit, filtration units, water softening unit and reverse osmosis as the main treatment unit. Autodesk inventor software was used in the design and analysis of the locally constructed components. After the selection of the design process a reverse osmosis-based water treatment plant with 8 hours run time was constructed with water grade materials and processes. The treatment plant was tested using water samples from river Kaduna, water runoffs and pond from the Nigerian Defence Academy environs. The samples were tested at the Kaduna Water Board laboratory and the results obtained showed that the treatment unit was effective in removing all harmful microorganisms and adjusting all physiochemical properties of water to meet the Nigerian Standard for Drinking Water Quality. The filtration unit was capable of effectively reducing turbidity to the standard for all the water sample tested. The highest value of turbidity of raw water recorded was 1105 NTU and it was reduced to 4.05 NTU. The water softening units was effective for the removal of hardness to the desired standards; the highest value recorded at 208 mg/l was reduced to 60 mg/l. The treatment plant was also effective in stabilizing the PH of all the water samples to almost neutral as the PH values of all the treated water samples were between 6.8 and 7.10. The reverse osmosis unit was responsible for the removal of unwanted ions and heavy metals had high removal rate after testing except for Cadmium from river Kaduna sample which was 0.7408 ppm and reduced to 0.3407 ppm still higher than the recommended standard 0.03 ppm. At the end of this work it was observed that the water treatment plant was stable and consistent in treating water including the removal of heavy metals and that the efficiency of the removal of heavy metals can be improved by increasing the number of the reverse osmosis unit.

Keywords: water quality, ion exchange, filtration unit, water softening unit, reverse osmosis, military operations

INTRODUCTION

The major role of the military is to defend the territorial integrity of the country and its interests against external or internal aggression; Also, to assist the civilian community in time of emergency and during peace time. To execute its roles the military are found in places where there is little or no access to social amenities [1,4]. It is however, essential to provide supplies they need to maintain good health and support military activities. One of such resources is the availability of portable drinking water. Planning the troupe drinking water demands is a complex procedure that involves understanding the environmental conditions, duration of stay, and intensity of activities among many others.

This creates a major logistical burden of transporting treated water using water tanks or bowsers; this problem is further compounded in bad terrains where the roads are dilapidated or in existent. Downtime to and from these locations to provide clean drinking water could be dangerous and costly as it increases fuel consumption as a result, water supply and transport is said to be one of the largest military logistical supply burden [2].

Some locations for military trainings may have the presence of surface water like rivers and ponds but this resource cannot be harnessed because surface water is characterized by the presence of harmful microorganisms, high solid contents, bad odour and taste. This natural resource can only be used if adequate treatment is carried out on the raw water supply. This led the Nigerian Defence Academy to design and construct its first water treatment unit [7,10].

Several models of water treatment units have been in use in the Nigerian Defence Academy. These models were effective but had their limitations. The need for innovation was based on the following requirement; increased water production capacity, reduced power usage reduced maintenance, minimize logistics of assembling water treatment, maximize reliability, improve portability of the water provided and ease of mobility [3].

The treatment plant was constructed by Jafaru et al (2017), Post Graduate Diploma Students of the NDA Department of Mechanical Engineering. It was constructed using plastic materials and consisted of five distinct stages raw water abstraction unit, chemical dosing unit, pre settling tank, sedimentation and filtration unit, one water dispensing tap and a single pump of 1hp was used for the whole unit [5].

This unit was bulky, the process was slow and the material use couldn't withstand the turbulence during road transport. This is reflected in the Figure 1.

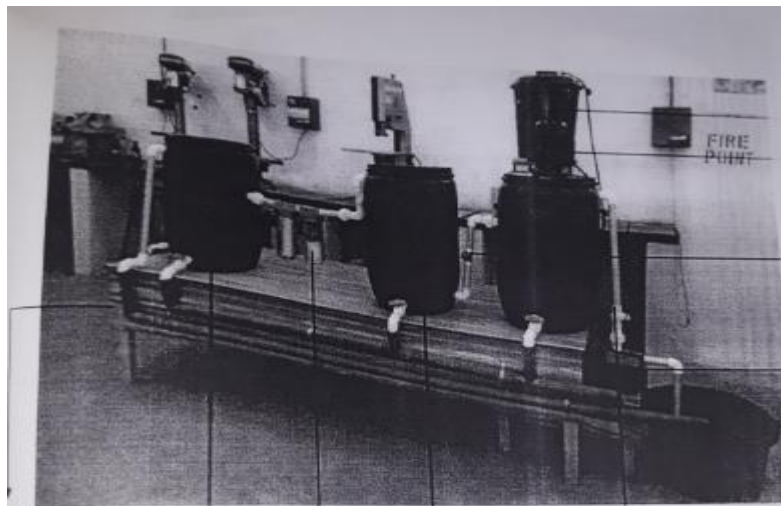

Figure 1. NDA Water Treatment Unit I

NDA Water Treatment Unit II

The former Chief of Army Staff, Lt. General Tukur Buratai (Rtd.) and former NDA Commandant Major General O. Oyebade having been impressed with the water treatment plant sponsored the production of an improved version. The Mechanical Engineering Research and Development team led by Associate Professor DK Garba designed an improved water treatment plant based on the principles of the two previous ones they produced. This was due to the authority's desire for constant supply of clean water during military trainings and camp exercises to save cost of providing water for the operations. The treatment unit was made up of primary flocculation and settling methods, filtration and chlorine treatment; this method was effective as it eliminated most disease-causing contaminants and gave high assurance that the water would meet the drinking water standards. It was upgraded to include solar power, better pumps were used, stainless steel materials were used for the construction, the number of dispensing taps was increased and most importantly the system was made to be demountable [1]. This improved version is shown in Figure2.



Figure 2. NDA Dual Powered Demountable Water Treatment Unit II

The motivation for this design was to study and identify the various deficiencies arising from previous, develop a treatment flow process that can effectively treat water from most natural water sources without the use of chemicals designs, and customize the design to a 5 tons Tata LPTA 713/32 military truck for easy movement.

MATERIALS AND METHOD

Materials

The materials used for the fabrication of the machine were carefully selected based on their physical, mechanical and chemical properties as well as the cost and the area of application. Other factors are the fabrication process employed and the required shape.

The major materials used for the construction of the plant are:

Stainless steel sheets, mild steel angle iron Stainless steel pipes, stainless steel rods, stainless steel 309 electrodes, helicon rods, Bearings Bolts and nuts 1hp suction pump, centrifugal water pumps 0;75 hp and 2hp, PVC pipes, joints and fittings, butterfly and ball valves, PVC gum, two reverse osmosis treatment unit, large blue filter, Epoxy mastics paint, Purolite activated carbon, Purolite weak acid ion exchange unit, coarse sand, fine sand, gravel, so clear ultraviolet light, gasket, tap, power box, thread seal tapes, sealing adhesive, control panel, knife switch, chaka metal switch.

Equipment

Some of the machine tools and equipment used during the cause of construction of the water treatment plant are:

Rolling machine (Hema Engineering Manual Mechanical Rolling/Bending machine 50-100mm), welding machine ((Juba AC Arc Stick Welding Bx 1-400 Amp mma Inverter DC 220V/380V, Ce Rohs Cccc 50/60 Hz 100),Drilling machine (Bosch GBM 1000 SKU:06011A90K1: 1.20KGS), grinding machine (Bosch GWS8-45 4-1/2-inch Angle Grinder 7.5-Amp motor 120 volts), cutting disc (Bosch Cutting Disc 355mm SKU 2608602 759; 0.11KGS), hacksaw, snip, scribe, measuring tape, try square, wrench, hack saw, hammer, pvc gum, spanner, plier, tape, screwdriver, files.

Description of the Water Treatment Plant

The plant parts are designed such that it can be easily assembled and disassembled and carried on a Tata LPTA 713/32 military grade truck, and most importantly make water treatment simple.

The major work of the whole plant is to treat water of any level or degree of impurity ranging from surface water to some industrial waste and heavy metals such that it can be fit for human consumption and also for agricultural purposes. The schematic representation of the treatment process is shown in Figure 3.

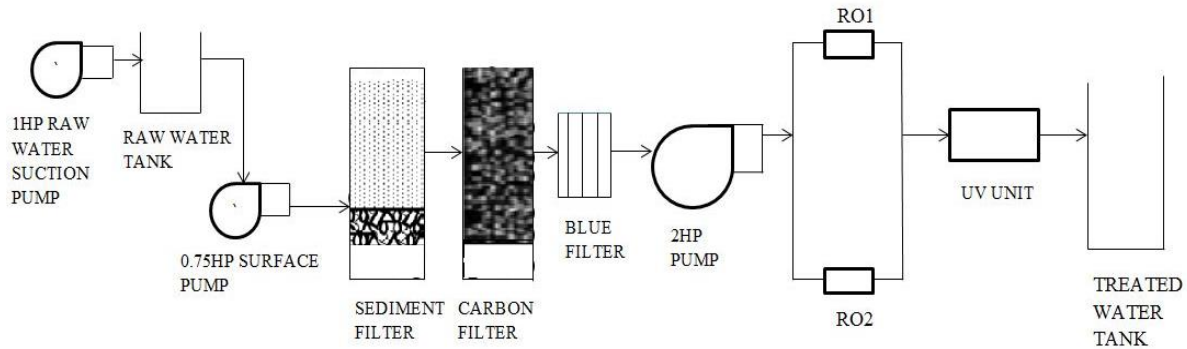

Figure 3: Schematic representation of the treatment flow process for the mobile treatment unit.

Raw water is pumped by a suction pump into the raw water tank and by the means of a hydraulic pump the raw water flows to the sediment filter unit that contains both sand filter and activated carbon to remove debris and hardness; it then flows to the carbon filter which contains both carbon and ion exchange resin where odour, iron and other contaminants are removed. Water flows from the carbon filter to the blue filter which is the final stage of pre-treatment before it is pumped with a higher capacity pump to the reverse osmosis membrane treatment unit where most contaminants like ions, metals, particles, pesticides, radio nuclides and harmful microorganisms are removed. The water then flows to the Ultra violet treatment unit which uses ultra violet rays to destroy harmful microorganisms that escaped from the treatment process. Disinfection by the ultraviolet unit is the final phase of treatment process after which the treated water is stored in the treated water tank for consumption [8,9].

Table1

Nomenclature	
Where l_b = length of the base	h_r = height of the raw water tank
b_b = breadth of base	Q = Flow rate (m^3/min),
l_c = length of the cut part of the base	P = pressure (psi),
b_c = breadth of the cut part of the base	E_{pump} = water pump efficiency
V_R = volume of raw water tank	BHP = Brake horse power
r_r = radius of raw water tank	E_{motor} = Drive motor efficiency
$\pi = 3.142$	P_{Ts} = total power input for sediment filter pump
r_s = radius of the sediment tank	P_{Tc} = total power input for carbon filter pump
h_s = height of the sediment tank	$P_{Tfilters}$ = Total power input requirement for filters
V_s = volume of the sediment tank	F = allowable load,
V_f = Volume of filtered water chamber	n = factor accounting for the end conditions,
V_{sc} = volume of chamber housing the sediment materials	E = modulus of elasticity
V_s = Volume of sediment tank	L = length of column (m)
V_f = Volume of filtered water chamber	I = Moment of inertia (m^4)
r_c = radius of the carbon treatment tank	
h_c = height of the carbon treatment tank	
V_c = volume of the carbon treatment tank	

continued

V_{cc} = volume of chamber housing the activated carbon and ion resin L_f = Length of frame W_f = Width of frame H_f = Height of frame V_T = volume of treated water tank r_t = radius of treated water tank h_t = height of the treated water tank	
---	--

Design

i. Total water requirement for a soldier

The daily water requirement for a soldier was calculated to factor the water requirement of an active person 0.00333 m³, addition for dryness 0.000473 m³ and the addition for strenuous activity 0.000473 m³ giving a total of 0.004276 m³/day (4.279 liters/day) [2].

Total daily water requirement for a soldier = Water requirements for an active person + Addition for dryness + Addition for strenuous activity----- (1)

ii. Amount of daily treated water

The reverse osmosis unit was designed to 0.0045 m³/min (4.5 liters/min) using the plant runtime of 8 hours, the plant could effectively treat 2.16m³ of water per day

Amount of water treated daily (8 hours run time) = Required flow rate after reverse osmosis treatment (m³/min) *60*8 -----(2)

iii. Number of cadets' water treatment plant can serve

The number of cadets that can get their daily drinking water was calculated using equation (3) below and the value was found to be 505 cadets

Number of cadets = $\frac{\text{Amount of water treated daily}}{\text{total daily water requirements}}$ -----(3)

iv. Surface Area of base/platform

Total surface area of base/platform = $l_b * b_b$ -----(4)

Surface area of cut part of base/platform = $l_c * b_c$ -----(5)

Surface area of uncut part of base/platform = Total surface area – Surface area of cut part of base/platform----- (6)

v. Volume of raw water tank

$V_R = \pi r_r^2 h_r$ ----- (7)

vi. Raw water tank retention time

Raw water tank retention time = Tank volume (m³) / flow rate (m³/min) -----(8)

vii. Pumps selection

Brake horse power (BHP) = $\frac{Q * P}{1717 * E_{pump}}$ -----(9)

viii. Total power input requirement (Energy use rate)

$P_{total} = \frac{BHP}{E_{motor}}$ -----(10)

ix. Total power input requirement for filters

$P_{Tfilters} = P_{Ts} + P_{Tc}$ ----- (11)

x. Volume of sediment treatment tank

$$V_s = \pi r_s^2 h_s \text{-----(12)}$$

$$V_f = 0.33 * V_s \text{-----(13)}$$

$$V_{sc} = V_s - V_f \text{-----(14)}$$

xi. Volume of carbon treatment tank

$$V_c = \pi r_c^2 h_c \text{-----(15)}$$

$$V_f = 0.33 * V_c \text{-----(16)}$$

$$V_{cc} = V_c - V_f \text{-----(17)}$$

xii. Frame

Eulers column formula for buckling of columns

$$F = \frac{n\pi^2 EI}{L^2} \text{-----(18)}$$

$$\text{Total surface area of frame} = 2(L_f W_f + W_f H_f + H_f L_f) \text{-----(19)}$$

$$V_T = \pi r_t^2 h_t \text{-----(20)}$$

Plant description

Autodesk inventor software was used in the design and analysis of the locally constructed components and all the dimensions are given in millimeters.

Base/Platform

The base/platform was designed to fit into the military grade Tata 713/32 military grade vehicle with a gross weight of 23000kg and payload capacity of 2500kg. The internal dimensions of the part of the truck to be used are shown below;

Length = 3200.4mm

Width = 2057.4mm

Height = 1422.4mm

The base was designed to carry all the treatment units and can be assembled and disassembled from the vehicle. It was coated with antirust and several layers of paint to make it highly corrosion resistant. A cut part was also included for technicians during maintenance for technician to stand on to prevent always standing on the platform.

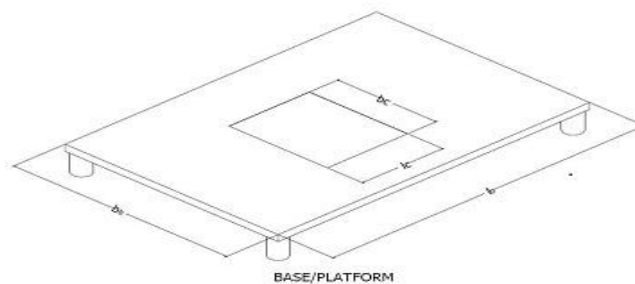

Figure 4: Platform for the water treatment plant.

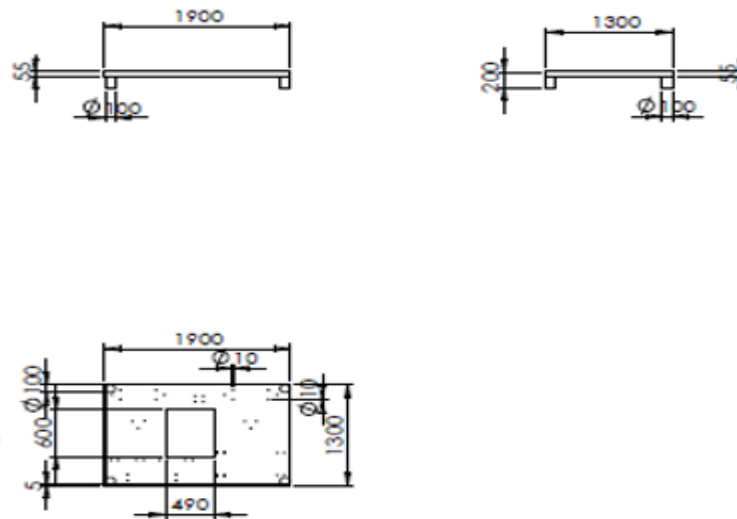

Figure 5: Dimensions of the platform

Raw and Treated Water Tanks

The raw water tank is the first unit which houses the raw water before proceeding to the first stage of treatment. It is cylindrical in shape so that raw water can easily be pumped in and out. The tank's volume determines the volume or quantity of water it can house. It has a cover at the top with an inlet and outlet opening. The inlet is located at the top where the water enters into the tank while the outlet is located at the bottom where water is being pumped out for the first stage of treatment to take place. It has three legs which are screwed to the base/platform so that it can be fixed on the base/platform. The raw water tank and clean water tank are used for storing untreated and treated water respectively. They are with inlets and outlets for taking water in and out. Also, the tanks are fitted with covers that can withstand road turbulence without spilling. The material of choice is the stainless steel because of its corrosion protection, durability, hygienic and biodegradability [15].

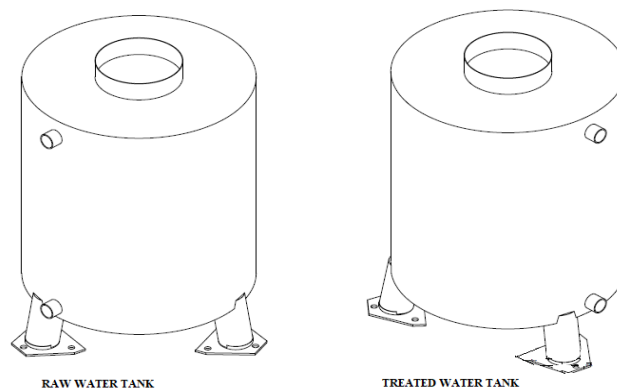

Figure 6: Raw and treated water tanks

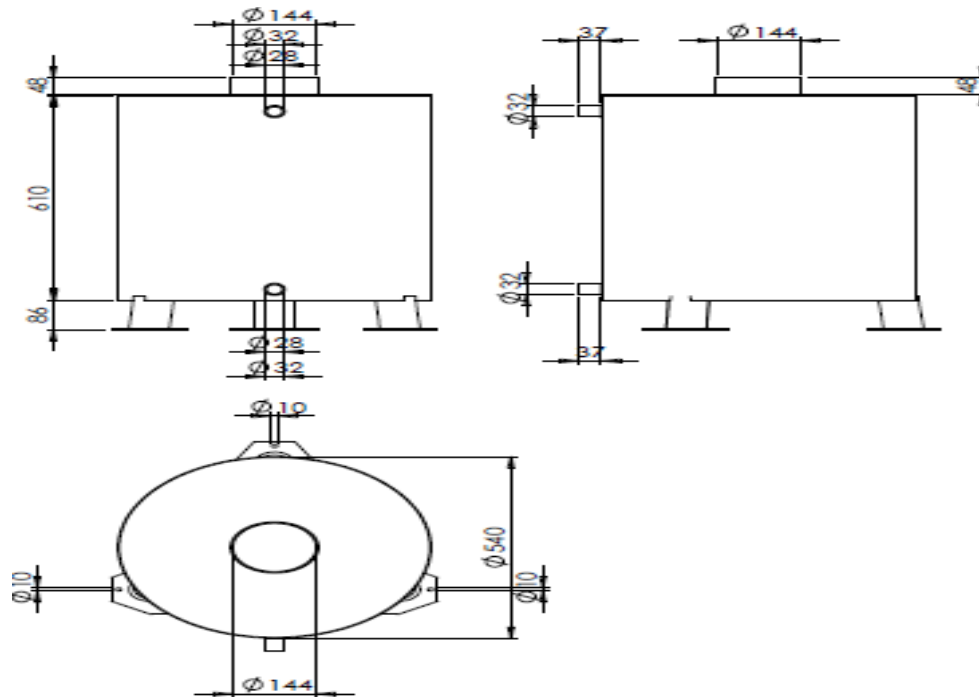

Figure 7: Dimensions of the raw and treated water tanks

Sediment and Carbon Treatment units

These units serve as the first stage of the treatment process. They are made up of two tanks as shown in figure 6. They both have openings at the top where treatment materials are being fed into the tanks and also at the bottom rear side. The openings at the rear side are for collecting treatment materials. They also have inlet and outlet openings where raw water enters and pre-treated water leaves to the next stage of treatment. The internal parts of the tanks are designed such that more than half of the tank is for treatment material while the other remaining part contains the pre-treated water. They have openings at the bottom of the tanks for back washing [13,14].

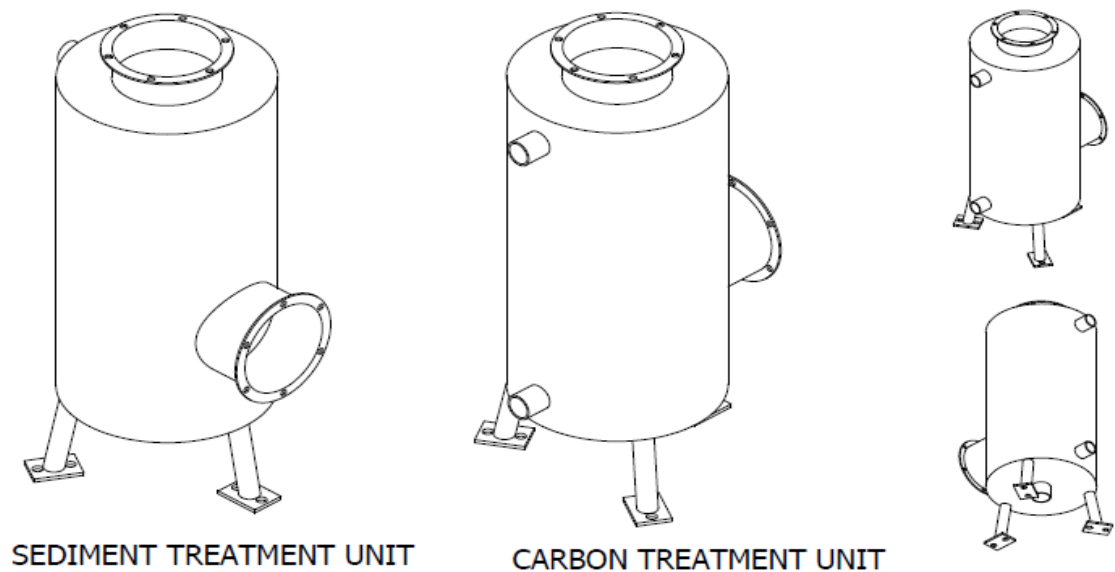

Figure 8: Sediment and Carbon Treatment Unit

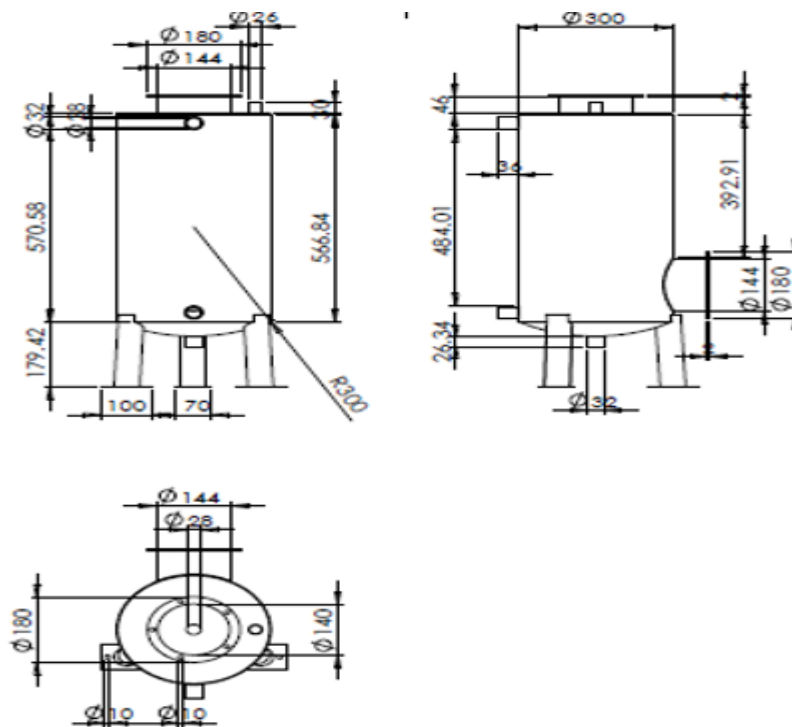

Figure 9: Dimensions of carbon and sediment units

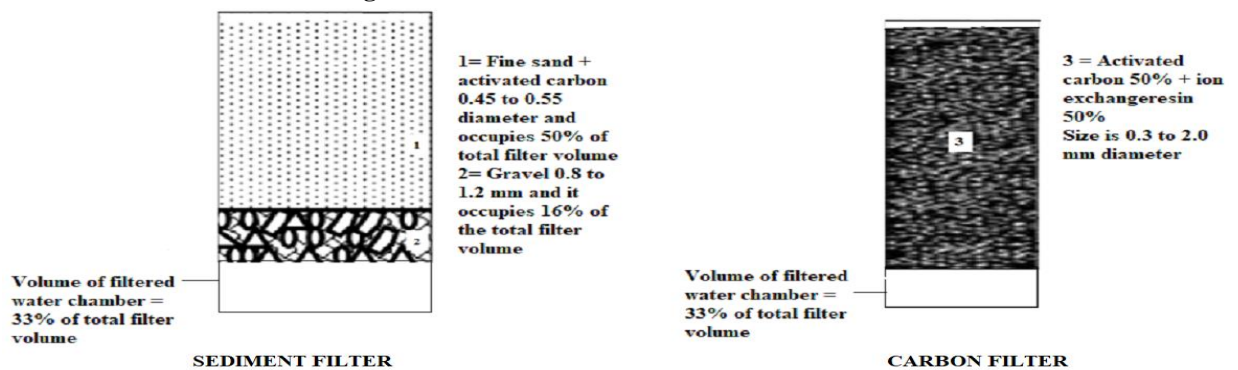

Figure 10: Showing the profile and composition for the sediment and carbon filters

Blue Filter

This unit is the next stage of treatment after the treatment tanks unit. It has a cartridge 114mm x 508mm, has pressure relief and outlet of 25mm and it can take pressure of up to 90 liters/min. It is the last stage of pre-treatment before the reverse osmosis treatment unit.

Reverse Osmosis Unit (RO)

Reverse Osmosis Treatment Unit comes after pretreatment units (sand and sediment filters, and the blue filter unit) and it treats water by pushing it under pressure through a semi permeable reverse osmosis membrane removing all ions and metals, particles, pesticides, radio nuclides and harmful microorganisms. A single pass reverse osmosis unit works at 75% efficiency while a double pass works with 90% efficiency. The unit was constructed to have two passes for optimal treatment. The unit was constructed using a high-quality membrane (thin film composite membrane) and would consist of a raw water feed in port, a treated water outlet port and rejected water outlet port. It uses a hollow fiber module this module has bundles of fine fiber membrane (0.1-2mm diameter) and is sealed in a tube. For reverse osmosis systems this is an effective module because of its ability to have more membrane sheets of large surface area in a small volume. This translates to better separation treatment process and good quality of permeability [14,16].

Ultra Violet Treatment Unit

This treatment unit was designed with a bulb inside a casing. The unit has an opening for inlet of water and also an outlet. It emits UV ray that kills bacteria and other bio-particles that escaped from the RO Unit, thereby making the whole treatment process complete and making raw water fit for human consumption. The ultraviolet unit selected has high and low-pressure, high output lamp. These lamps are cheap to replace, and generally the initial equipment cost is much lower as well. The rate of transmission of ultraviolet light for the unit selected ranges from 254 to 260 nm wavelength because the highest deactivation occurred at 260nm making the unit highly suited for final disinfection. Operating temperature of 60 to 200°C, Electrical input (W/cm) of 1.5 to 10, electrical to germicidal UV conversion efficiency of 35-38%, germicidal UV output of 0.5-3.5 W/cm and lifetime of 8000 to 12000 hours [11].

Frame

A frame was designed to carry the ultraviolet treatment unit, reverse osmosis unit, blue filter, pump and power box. This was necessary due to the space constraint in the vehicle provided.

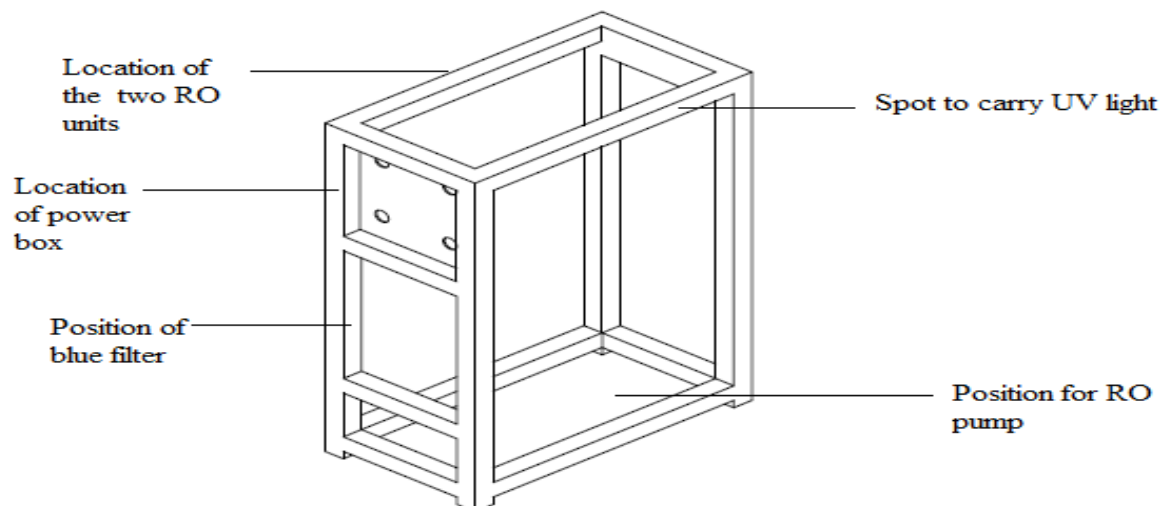

Figure 9: Frame

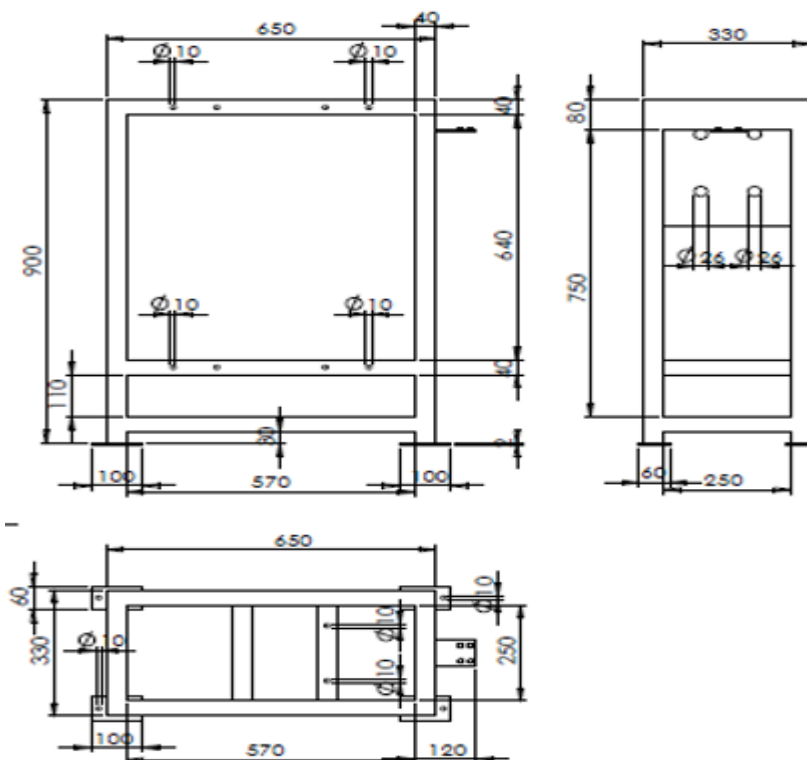

Figure 11: Dimensions of the Frame

RESULTS AND DISCUSSION

Results

The results of the Bacteriological Analysis for all the samples (both treated and raw water) are given in Table 2. The analysis was carried out on the treated water samples as the samples of interest.

Table 2: Bacteriological Analysis

S/NO.	LOCATION	General Bacteria Count on Nutrient Agar at 37°C IN 48hrs Cfu/ml	Most Probable Number of Coliform Organism MPN/100ml	Most probable Number E. coli MPN/100ml
	NSDWQ STANDARD	500/ml	Nil	Nil
1.	Treated water from Sample A	Nil	Nil	Nil
2.	Treated water from Sample B	Nil	Nil	Nil
3.	Treated water from Sample C	Nil	Nil	Nil
4.	Treated water Sample from Kaduna River	Nil	Nil	Nil
5.	Treated water Sample from NDA	Nil	Nil	Nil

The results of the physiochemical analysis for all the samples (both treated and raw water) are recorded in the Table 3.

Table 3: Physio-Chemical Analysis

S/N	PARAMETERS	RAW WATER (RIVER KADUNA)	TREATED WATER RIVER KADUNA	RAW WATER (SAMPLE A)	TREATED WATER (SAMPLE A)	RAW WATER (NDA POND)	TREATED WATER (NDA POND)	RAW WATER (SAMPLE B)	TREATED WATER (SAMPLE B)	RAW WATER (SAMPLE C)	TREATED WATER (SAMPLE C)	NSDWQ STANDARD
1	Turbidity (NTU)	80.40	4.40	12.00	4.20	96.4	4.10	85.2	3.80	1,105	4.05	0-5.0
2	PH Value	6.50	7.10	6.20	7.00	6.60	6.90	6.40	7.30	6.30	6.80	6.5-8.5
3	Conductivity μ S/cm at 25°C	49.80	20.6	22.8	6.50	78.8	17.20	16.00	8.00	78.60	10.10	400
4	Chlorides as CL mg/L	32.98	1.97	24.99	1.21	20.99	0.99	13.99	1.11	17.99	0.52	250
5	Nitrates as N mg/L	0.14	0.002	0.12	0.001	0.030	0.01	0.13	0.001	0.028	0.001	5
6	Bicarbonate Alkalinity As CaCO ₃ mg/L	44.00	8.00	48.00	12.00	48.00	12.00	42.00	7.00	38.00	6.50	500
7	Carbonate Alkalinity As CaCO ₃ mg/L	Nil	Nil	Nil	Nil	Nil	Nil	Nil	Nil	Nil	Nil	
8	Total Alkalinity As CaCO ₃ mg/L	44.00	8.00	48.00	12.00	48.00	12.00	42.00	7.00	38.00	6.50	200
9	Total Hardness As CaCO ₃ mg/L	166.00	40.00	60.00	10.00	208.00	60	96.00	45.00	66.00	30.00	150
10	Total Iron as fe mg/L	0.19	0.010	0.14	0.010	0.98	0.1	0.12	0.09	0.14	0.09	0.5
11	Silica as SiO ₂ mg/L	0.19	0.13	0.14	0.09	0.98	0.10	0.12	0.05	0.10	0.08	50
12	Sulphate as SO ₄	13.00	5.00	9.00	3.00	38.00	9.00	34.00	8.00	28.00	6.00	200
13	Free carbon dioxide mg/L	32.00	8.00	24.00	5.00	38.00	10.00	34.00	8.00	28.00	6.00	
14	Calcium mg/L	156.00	40.00	56.00	30.00	202.00	60.00	84.00	32.00	64.00	28.00	100
15	Total dissolved Solid mg/L	24.90	10.09	11.40	4.15	39.00	11.00	25.35	13.00	39.3	11.00	500
16	Ammonia (as NH ₄ ⁺)	10.00	0.3	6.00	0.2	12.00	0.4	6.00	0.2	8.00	0.5	0.5

Table 4: Heavy Metals Analysis

Only the sample from the River Kaduna was tested as other samples did not test positive for heavy metals.

S/N	Name of Metal	Amount in Raw Water (ppm)	Amount in Treated Water (ppm)	NSDWQ Standard
1	Cadmium	0.7408	0.3407	0.03
2	Zinc	-0.7683	-0.8614	3.0
3	Arsenic	-0.0348	-1.1078	0.01
4	Lead	0.0401	0.010	0.01
5	Copper	-0.1075	-0.1174	2.00

DISCUSSION OF RESULTS

Bacteriological Analysis

The result obtained after treatment for all samples showed that there is no presence of bacteria or disease-causing pathogens in the water.

Physio-Chemical Analysis

The results from the physiochemical analysis showed that for all the parameters analyzed the values above the recommended values were reduced to the recommended values. While those that were already in the acceptable range was further reduced. The filtration unit was capable of effectively reducing turbidity to the standard for all the water sample tested. The highest value of turbidity of raw water recorded was 1105 NTU and it was reduced to 4.05 NTU. The water softening units was effective for the removal of hardness to the desired standards; the highest value recorded at 208 mg/l was reduced to 60 mg/l. The treatment plant was also effective in stabilizing the PH of all the water samples to almost neutral as the PH values of all the treated water samples were between 6.8 and 7.10.

Heavy Metals Analysis

The treatment plant was tested to see how it removes some major metals from the raw water samples. All samples were tested for metals but only the sample from river Kaduna showed the presence of heavy metals and hence was used for the analysis. The table 4.3 showed the amount of different metals present in raw water, the amount present after treatment and the corresponding NSDWQ standards.

The results with the negative sign from zinc, arsenic and lead denote almost insignificant values of the metals present in raw water, the system responded by taking it further to the negative side and to the world health organization accepted values. But for the positive values, Cadmium was 0.7408 before treatment and 0.3407 after treatment while lead was 0.0401 before treatment and 0.010 after treatment.

The amount of Cadmium in the treated water was still above the recommended value of 0.03 while lead was at the recommended value of 0.01. The percentage removal for lead and Cadmium was calculated by subtracting the amount of metal in treated water (ppm) from the amount in raw water (ppm) divided by the amount in raw water (ppm) and expressing it in percentage.

The percentage removal for Cadmium was 54.01% while that of lead was 75.1%. The major part of the treatment unit responsible for the removal of heavy metals is the reverse osmosis unit. The results obtained used as a guide to test the efficiency of the unit.

The system currently works with two reverse osmosis membrane, from the results obtained the efficiency of the removal of heavy metals can be improved by adding two or more membranes to the original design.

Consistency Test

In other to ascertain how the consistency of treatment done by the system one sample was picked and treatment was conducted three times and the results of the four major tests namely; bacteriological, turbidity, PH and hardness was recorded to check if the results was consistent. The sample selected for this test was the sample collected from NDA river. The results are shown below;

Table 5: Consistency Test of Bacteriological Analysis

Tests	General Bacteria Count on Nutrient Agar at 37°C IN 48hrs Cfu/ml	Most Probable Number of Coliform Organism MPN/100ml	Most probable Number E. coli MPN/100ml
Test 1	Nil	Nil	Nil
Test 2	<500	Nil	Nil
Test 2	Nil	Nil	Nil

In all the three tests carried out using the same sample, the treated water sample was free from disease causing microbes which means that the system was consistent in the removal of harmful microorganisms.

Table 6: Consistency Test of Physiochemical Analysis

Tests	PH (Raw water)	PH (Treated water)	Turbidity (Raw water)	Turbidity (Treated water)	Hardness (Raw water)	Hardness (Treated water)
Test 1	6.60	7.0	96.4	3.80	208	60
Test 2	6.60	6.9	96.4	3.0	208	69
Test 3	6.60	6.9	96.4	2.5	208	67

From the results obtained above to get the coefficient of variation in data, the standard deviation was calculated and divided by the mean of the data provided.

As soon below Coefficient of Variation (CV) = Standard deviation (SD)/ Mean

PH values = 0.057735/6.933333 = 0.008327

Turbidity Values = 0.655744/3.1 = 0.072334

Hardness Values = 4.725816/65.33333 = 0.072334

A CV of greater or equal to one denote high variation in data which not desirable in this case as it would mean that the system is not consistent and efficiency is low. However, the CV values obtained were less than one which means low variation in the data obtained meaning the efficiency of the system was somewhat consistent.

CONCLUSION

The design and construction of the mobile potable water treatment plant was successfully completed and it was able to meet all the required objectives. The treatment plant could effectively remove all harmful microorganisms and maintain Nigerian Standard for Drinking Water Quality NSDWQ without the use of chemicals unlike the other models available irrespective of the raw water source. The treatment time was significantly faster than the previous models. Designed to work for 8 hours daily, it could treat 2.16 m³ of water per day serving 505 cadets their daily water requirements with no time lapse per treatment cycle. The treatment plant integrated well into the military truck provided to carry it and the use of dual power was

effectively accomplished. The treatment plant was effective in stabilizing the PH of all the water samples to almost neutral as the PH value of all the treated water samples was between 6.8 to 7.10. The filtration unit was capable of effectively reducing turbidity to the standard for the entire water sample tested. The highest value of turbidity obtained was (from sample C) 1105 NTU which was reduced to 4.05 NTU giving results of very clear water. The constructed water softening units was effective for the removal of hardness to the desired standards. The highest value recorded was from NDA pond at 208 mg/l which was reduced to 60 mg/l. The reverse osmosis unit responsible for the removal of unwanted ions and heavy metals had high removal rate after testing except for Cadmium which was reduced but not to the recommended standard. Finally, all physiochemical properties of water were adjusted to the Nigerian Standard for Drinking Water Quality irrespective of the amount present in raw water samples.

REFERENCES

- [1] Huizinga R. P and Enserink B., (2020), Water in Military Stabilization Operations: Compressive Water Intervention Framework for Conflict Management and Peacekeeping, <https://doi.org/10.2166/wp.2020.207> Pp 85-101.
- [2] https://www.goarmy.com/soldier-life/fitness-and-nutrition/components-of_nutrition/hydration.html US Army Magazine, Hydration [accessed 7/9/2020]
- [3] Nisha Charkoudian; Robert W. Kenefick; Anthony J. Lapadula; Albert J. Swiston; Tajesh Patel; Laurie A. Blanchard; Elizabeth M. Caruso; Anthony J. Luippold; Samuel N. Cheuvront, (2016), Planning Military Drinking Water Needs: Development of a User-Friendly Smart Device Application Pg 181, 9:1142.
- [4] Garba, D.K (2018) Design and Construction of Dual Powered Dismountable Treatment Plant for Chief of Army Staff. Department of Mechanical Engineering NDA (unpublished)
- [5] Jafaru A. and Umar Zango, (2017) Design and Construction of Demountable Treatment Plant for Cadet Field Trip. Post Graduate Diploma Project Department of Mechanical Engineering NDA Post Graduate School Kaduna (unpublished).
- [6] https://www.researchgate.net/post/Water_Treatment_Plant_Efficiency [Accessed 19th December 2020].
- [7] Homeland Security News Wire (2013, June 28). Improved Water Purification Technology Reduces Logistical Burden. Available from <http://www.homelandsecuritynewswire.com/dr20130627-improved-water-purification-technology-reduces-logistics-burden>. [Accessed 29th April 2020]
- [8] Spellman F.R (2003) Handbook of Water and Waste Water Treatment Plant Operations Boca Raton, Florida, CRC Press LLC
- [9] Drinan, J.E., (2001), Water & Waste- Water Treatment: A Guide for the Non-Engineering Professional, Technomic Publication, Lancaster, PA, pp.2–3.
- [10] Smith, R.K., (1995), Water and Wastewater Laboratory Techniques, Water Environment Federation, Alexandria, VA, p.13
- [11] Demers, L.D. and Renner, R.C., (1992), Alternative Disinfection Technologies for Small Drinking Water Systems, Denver, CO, American Water Works Association and American Water Works Association Research Foundation.
- [12] Radin Mohamed, Radin Maya Saphira & Adnan, Mohamad & Mohamed, Mohd & mohd kassim, Amir Hashim. (2016). Conventional Water Filter (Sand and Gravel) for Ablution Water Treatment, Reuse Potential, and Its Water Savings. Journal of Sustainable Development. 9. 35. 10.5539/jsd.v9n1p35.
- [13] Churchill, Jack & Mumford, Kathryn. (2020). Granular Activated Carbon in Water Treatment. 10.1201/9781351032308-13.
- [14] Drinan, J.E., (2001), Water &Waste- water Treatment: A Guide for the Non engineering Professional, Technomic Publ., Lancaster, PApp.2–3.
- [15] Design Recommendation for Storage Tanks and Their Supports with Emphasis on Seismic Design (2010 Edition) Architectural Institute of Japan.
- [16] Pros And Cons of Storage Water Tanks Available In Different Materials Posted by [ozfetch](https://neconnected.co.uk/pros-and-cons-of-storage-water-tanks-available-in-different-materials/) Aug 30, 2018 | <https://neconnected.co.uk/pros-and-cons-of-storage-water-tanks-available-in-different-materials/>[Accessed 24th November 2020]
- [17] Gagliardi, M.G. and Liberatore, L.J., (2000), Water Piping Systems, in Piping Handbook, 7th ed., Nayyar, M.L., Ed., McGraw-Hill, New York, p.C-26.
- [18] Spellman, F.R. and Drinan, J., (2001), Water Hydraulics, Technomic Publ., Lancaster, PA.

Design and Construction of a Dual Powered Reverse Osmosis Based Mobile Water Treatment Plant for Military and Emergency Use

- [19] Metcalf &Eddy, (1981), Wastewater Engineering: Collection and Pumping of Wastewater, McGraw-Hill, New York, p.11.
- [20] https://www.researchgate.net/post/Water_Treatment_Plant_Efficiency [Accessed 19th December 2020].